

SYSTEMATIC QUALITY

CircLED



Product information



GIFAS
ELECTRIC

09 | 25

Introduction

Introduction



Page 3

Page 3

CircLED

Product /System

Technical data

Applications

Product range



Page 4

Pages 4 - 7

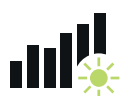

Page 5



Page 6



Page 7

Accessories

Control unit and remote control

Power supply

System components/mounting

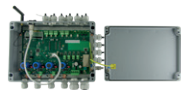

Page 8

Pages 8 - 11



Page 9

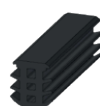

Pages 10 - 11

LED guidance systems – for safe traffic routing



CircLED

Our product line of optical guidance devices is applicable in tunnels, roundabouts or on the road in general.

We have detailed information, documentation, certificates for any of our systems which we would be appreciate to send if you are interested.

Why optical guidance systems?

An optical guidance device improves recognition of lanes or obstacles, particularly during times of poor visibility (at night, fog, etc.) as well as vulnerable traffic areas such as tunnels, curves, roundabouts or traffic islands. The signals provide a very high degree of safety for traffic.

The system complies with current regulations (BAST Germany, FEDRO Switzerland e.g.), and are continuous EMC-approved, which means, that the system functions with cables/wires and is non-inductive, so electromagnetic fields are excluded.

The wired systems are installed directly in the road surface. However, it is important that the installation area is not constantly driven over.

Our recess-mounted lamps are compatible with all GIFAS systems. They complement each other ideally and require the same system components, such as a control unit, feeder cable, etc.

All GIFAS systems can be dimmed across a continuous scale using the control unit or remote control.

Your benefits

- EMC-approved, no inductive interference
- quick and easy installation
- latest LED technology, very low power consumption
- vandal-proof, reinforced synthetic material/V4A Investment casting
- dimmable by control unit
- interoperable with all LED guidance systems
- modular construction, low-maintenance
- often set in systems in different applications
- thereby high product- and application know-how

Our services

- many years of know-how, experienced Project Manager
- individual advice, also on site
- large standard range, individual solutions possible
- expert advice on installation and bringing into service
- creating CAD documents, voltage drop calculations and tunnel disposals
- own service team with professional equipment and many years of know-how





CircLED recessed light

CircLED is used for specific applications, mounted as wall- or floorlamp. Main focus is the roundabout lighting, where it is used as security, control and design lighting. Used in addition to many other uses as path lighting (floor or wall mounting). The CircLED is available with integrated light optics as well as in several light colours. It should be noted that the CircLED is only partially suitable for permanent drive-over and snowplough operation.

System description

The CircLED will be flush mounted. The casing is made of chrome steel and the assembly has to be effected directly in the subgrade (asphalt, concrete, gravel, ground or the like).

Connection technology

The operating voltage is 20-48VDC (low voltage). The current is transmitted from the supply line (2x2.5mm²) in a suitable installation pipe and is inserted in the lower part. A clamp is used to connect the upper part, which is filled reversibly and screwed together.

Support in the fight against light pollution

Using CircLED helps to fight increasing light pollution. The light guidance is designed in such a way that the light output is only aimed at the defined and desired direction.

High energy efficiency to reduce costs

Sophisticated electronics with latest LED technology is leading to a very low power consumption. The total power consumption for an average roundabout of 20 pieces CircLED is similar to a single 60W bulb.

Sealing technology

The overall design of the individual components was based on a high degree of impermeability. Protection class IP68 is attained provided the assembly is performed by experts.

Control units

The control units required for supplying and/or controlling the light modules are small and space-saving and can usually be integrated in existing distribution systems or control cabinets. A small distributor may be installed as needed.

Product documentation

Installation instructions



Reference list



Declaration of conformity

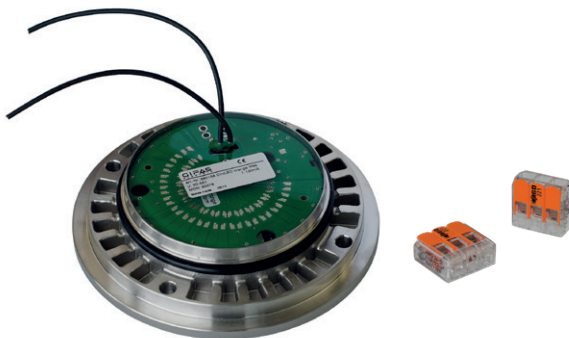

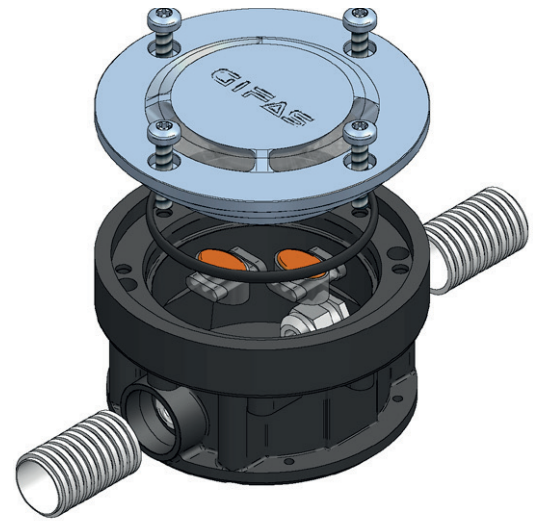

Technical data

270° circular emission along a light strip (16 LED)

Light colours:	white (5'600K/3'500K), blue (470 nm), orange (600-609 nm)
Luminous intensity:	20cd (white)
Illuminant:	16 LED with integrated optic
Operating life LED:	L90/B10 100'000h (white)
Protection category:	IP68
Protection class:	III
Operating voltage:	24VDC (range 20 - 48VDC)
Power consumption:	130 mA @ 24 VDC
Diameter:	120 mm
Height with floor pit:	73.5 mm
Upper part:	chrome steel V4A
Lower section:	IXEF glass-fibre reinforced polyarylamide, black
Height over road surface level:	3.5 mm
Temperature resistance:	-30°C to +55°C
Drive-over capability:	B125 according to DIN EN124

CircLED

- lower part made of special plastic IXEF
- upper part made of stainless steel
- electronics completely sealed
- the lightness of the light modules is easily adjustable by a control unit and can be manipulated by the automatically light control or direct control from tunnel centre office

Single components

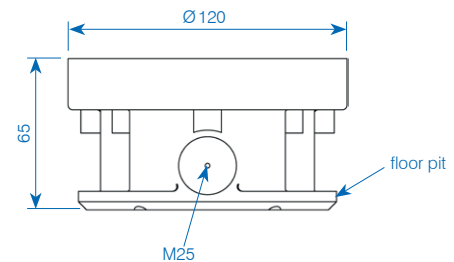
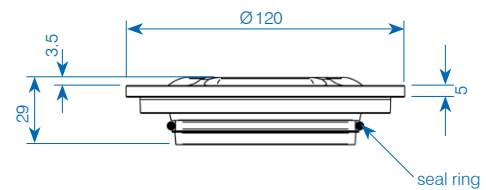

Certificates, reference list etc. available on request

Scheme light emission

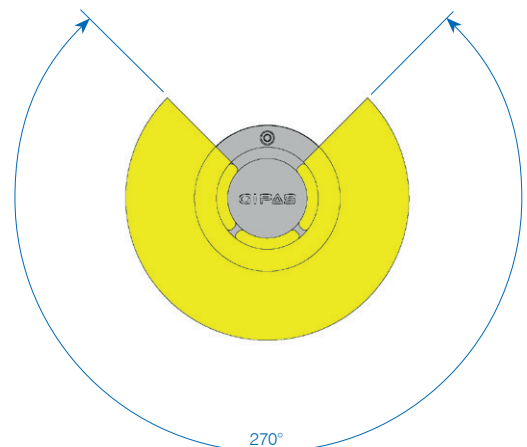
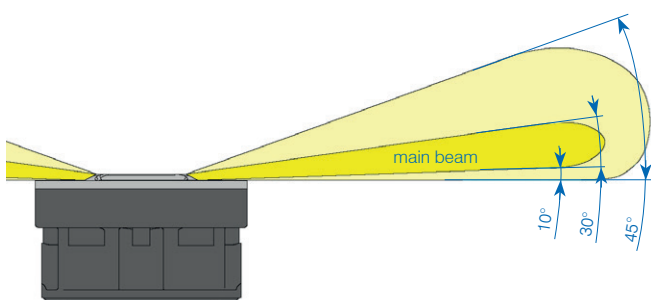



Roundabout Ottringen



Roundabout Buriel



Zurich Hardbrücke



Zurich Hardbrücke



Garden/hedge



Entrance area

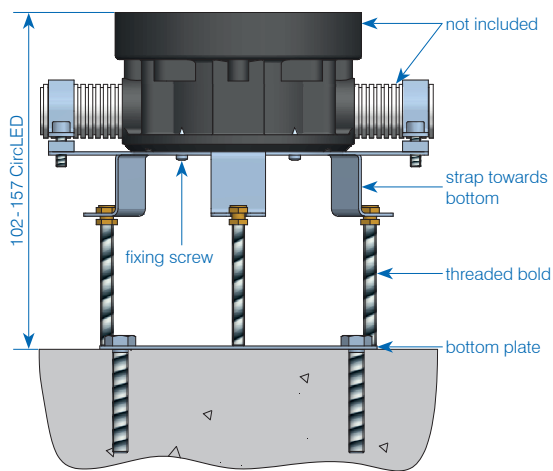
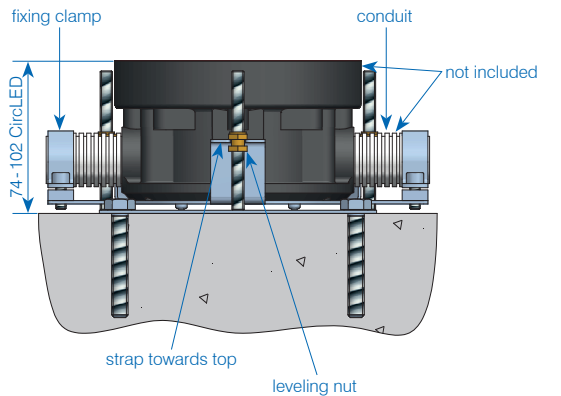

item no. 036106



item no. 038311



item no. 156537

Installation jig for CircLED

GIFAS provides a suitable installation jig for mounting the CircLED on loan. This makes it possible to adjust to the ground level exactly and to optimise the relocation of the component.



Item no.	Designation
174536	Installation jig (on loan by GIFAS)



Product range CircLED

Item no.	Designation
860156	CircLED light module V4A, 130 mA @ 24 VDC (20-48 VDC), 16×LED white 5'600 K
860160	CircLED light module V4A, 130 mA @ 24 VDC (20-48 VDC), 16×LED white 3'500 K
860157	CircLED light module V4A, 130 mA @ 24 VDC (20-48 VDC), 16×LED blue 470 nm
860158	CircLED light module V4A, 130 mA @ 24 VDC (20-48 VDC), 16×LED orange 600-609 nm
860346	CircLED light module V4A, 130 mA @ 24 VDC (20-48 VDC), 16×LED red 625 nm
031353	CircLED lower section Ø 120×65 mm, 1×M16 (Ø 4-9mm), casing plastic anthracite
036106	CircLED lower section Ø 120×65 mm, 2×M16 (Ø 4-9mm), casing plastic anthracite
153149	CircLED lower section Ø 120×65 mm, 1×M16 (Ø 4-9mm), casing plastic anthracite (for system cable flat)
153150	CircLED lower section Ø 120×65 mm, 2×M16 (Ø 4-9mm), casing plastic anthracite (for system cable flat)
185473	CircLED lower section Ø 120×65 mm, 1×M16 (Ø 4-9mm), 1×hose nipple M25, casing plastic anthracite
185482	CircLED lower section Ø 120×65 mm, 2×M16 (Ø 4-9mm), 2×hose nipple M25, casing plastic anthracite
190367	CircLED lower section Ø 120×65 mm, 1×M16 (Ø 4-9mm) from behind, casing plastic anthracite
190366	CircLED lower section Ø 120×65 mm, 2×M16 (Ø 4-9mm) from behind, casing plastic anthracite
156537	CircLED blind cover V4A, Ø 120×20.2mm, incl. seal ring and screws
038311	CircLED blind cover polypropylene natural, 120×7/12 mm (for temporary cover only)
037712	Levelling console V2A, range 85-168 mm
173496	System cable TPE-R halogen-free, black, 2×2.5 mm ² , Ø8.2mm, strands: red, black

other versions on request

4-channel control unit

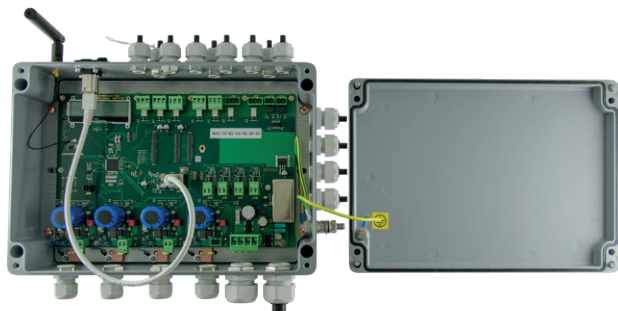

The control unit for all GIFAS systems is designed for 4 output lines. Each channel can be loaded with up to 10A.

- **Supply:** a 230VAC/24-48VDC power supply device with a nominal output current of 40A is installed upstream from the control unit.
- **Error messages:** each channel has a relay with SPDT (potential free) assigned to the signaling of error messages.
- **External blinking contacts:** by default, two external flashing signals (24-60VDC) can be connected and transferred to the outgoing lines (synchronisation with flashing signal).
- **Operating mode:** the control unit has 8 or 31 different modes of operation.
- **Failure rate:** by failure rate detection, the lights can be tested for their functionality. The control unit measures the total power consumption of the respective channel. If the power consumption drops to a preset value, the fault message can be detected via a changeover contact (potential-free).
- **Functions:** one of the following functions can be assigned to each channel in each mode:
 - continuous lighting: 100%
 - dimming: adjustable from 1-99%
 - flash: adjustable from 0.1-9.9Hz
 - lightning: adjustable from 1-99ms
 - running light: running light direction, dimming 1-99%, Light duty cycle 100ms-10sek, delay in lighting 100ms-10sek, switch-on delay 0-999sek, duty cycle 0-999sek
 - off
- **Programming:** the control unit can be optionally parametrised and read out via the web interface or the optionally available radio programming unit.
 - Web interface: if the control unit is connected to the network via RJ45 Cat. 6a, all parameters can be set and read out via a web browser.
 - Radio programming unit: the parameters can also be set by the radio programming unit.

Technical data

Protection category:	IP65
Rated power max.:	1'920VA
Input voltage:	18-48VDC
Supply current:	40A, 4 channels à 10A
Power supply:	external
Dimensions:	330×230×110mm

Item no.	Designation
860594	4-channel control unit in cast aluminium housing, IP65, 18-48VDC/4×10A, excl. power supply

Remote control to 4-channel control unit



Programming device with menu guide for set-up, programming and status recognition of the control unit. Communication with the control unit occurs through radio.

All necessary functions can be set up and assigned through the menu structure. No special knowledge is required to operate it. The connection between the control unit and the programming device is bi-directional, i.e. the current settings can be transferred from one to the other.

The buttons «↑», «↓», «☒» and «✓» are used to navigate the system. The range is approx. 3m.

The menu is available in four languages: German, English, French and Italian.

Technical data

Material:	ABS
Protection category:	IP40
Protection class:	III
Radio frequency:	2.4-2.525 GHz
Operating voltage:	4.5VDC, 3 batteries AAA
Life of battery:	> 1 year in standby mode
Dimensions (WxHxD):	73×140×32mm
Colour:	graphite grey similar to RAL 7024

Item no.	Designation
860460	Remote control to 4-channel control unit

Roundabout controller

The roundabout controller is the optimum control unit for simple applications, typically roundabout illumination. It is used to control the brightness and can be easily mounted on the wall because of the mounting plate which is included.

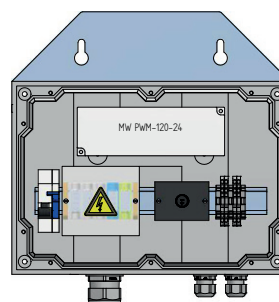

Item no.	Designation
212639	Roundabout controller with rotary potentiometer

Power supply to 4-channel control unit



A 230VAC/24/36/48VDC power supply is installed upstream from the 4-channel control unit. The power supply is equipped with integrated protection against overloading and short-circuiting, with automatic or manual reset.

The power supply conforms to CEE regulations and also has UL and/or CSA approval.

Technical data

Protection category:	IP20 (IP42 with additional cover)
Protection class:	I
Input voltage:	230 VAC (range 100 - 240 VAC)
Output voltage:	24 / 36 / 48 VDC
Output current:	10 / 20 A
Connections primary:	screw terminals 4 mm ²
Connections secondary:	screw terminals 4 mm ²
Status display:	LED green
Installation:	quick fastening for DIN rail 35 mm
Dimensions (W×H×D):	see designation below

 detailed datasheet of power supply available on request

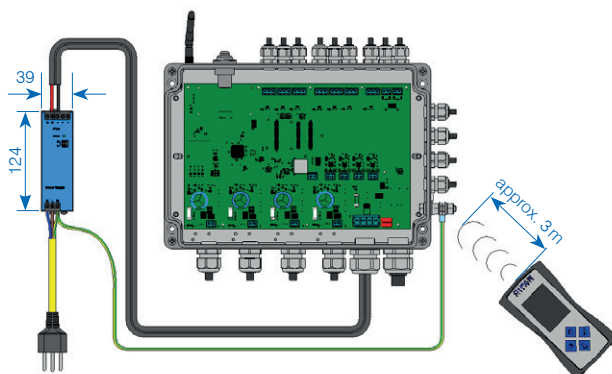

Item no.	Designation
163193	Power supply 230 VAC/24 VDC - 10 A/240 W 39 × 124 × 117 mm
136629	Power supply 230 VAC/24 VDC - 20 A/480 W 65 × 124 × 127 mm
202595	Power supply 230 VAC/48 VDC - 10 A/480 W 48 × 124 × 127 mm
180867	Power supply 230 VAC/48 VDC - 20 A/960 W 125 × 124 × 127 mm

other versions on request

Cold conductor monitoring



The cold conductor monitoring is used for detecting defective installations or lights that are not connected. The monitoring is automatically activated as soon as the lights are switched off.

- **Feeding:** a power supply 230VAC/18-48VDC with a rated output current of max. 10A is connected upstream of the cold conductor monitoring. The level of the output voltage of the power pack depends on the marking light used in this case.
- **Fault signal:** the cold conductor monitoring has two relays with change-over contact (potential-free) to signal fault messages for voltage interruption (for example, failure of the power supply unit) and exceeding of the failure rate (for example defect in the control unit installation).
- **Functions:** in every cold conductor monitoring, the threshold for the max. failure rate detection can be set individually in percentage. The adjustment range is 10-70% and can be adjusted in 10% increments.
- **Programming:** programming is done directly via the programming buttons on the control board or via the 4-channel control unit.

Technical data

Protection category:	IP66
Rated power max.:	480 VA
Input voltage:	18 - 48 VDC
Supply current:	10 A
Power supply:	external
Dimensions (W×H×D):	160 × 100 × 81 mm

Item no.	Designation
860603	Cold conductor monitoring in cast aluminium housing, IP65, 18-48 VDC, 10 A, excl. power supply

Fire-proof junction box

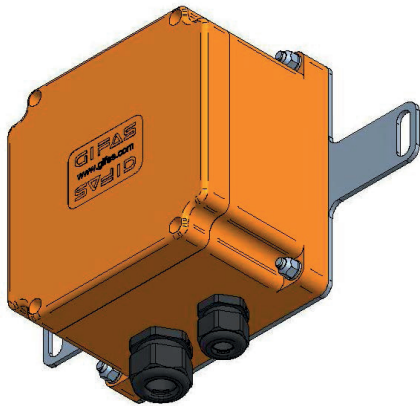

The safety cable must be connected from control center to the GIFAS system cable when connecting the signal units to the infrastructure. A special junction box is required for these connections. This can be installed in the cable trunks in the tunnel shoulder or at another suitable point. An E30/E60 junction box is usually required for this application. The size of junction box depends on the feed-in cable used as well as the number of outlets.

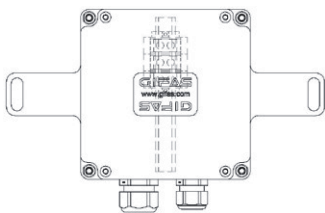

item no. 207643

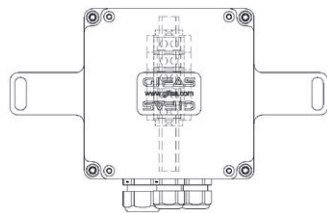

item no. 208762

Item no.	Designation
207643	Junction box FE180/E30 type 1616 orange polyester fibre, IP66/68, 3×6.0mm ² , 1×M20, 1×M25, incl. mounting plate
208762	Junction box FE180/E30 type 1616 orange polyester fibre, IP66/68, 5×6.0mm ² , 2×M20, 1×M25, incl. mounting plate

Joint profile

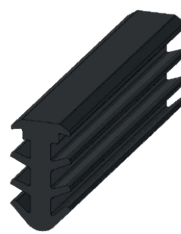

item no. 116753

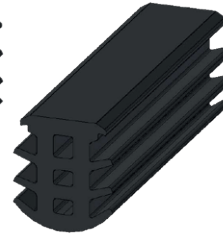

item no. 140862

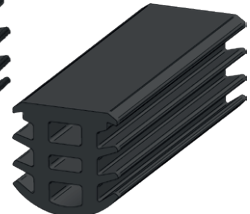

item no. 155809

The milled groove of the optical guidance system must be sealed against environmental conditions. A simple and low-cost solution is to use the halogen-free GIFAS joint profile made of EPDM. This is inserted in the slot. It is self-locking and available in three different widths. A stable and smooth slot with slot widths of 6 -15 mm is the prerequisite for use.

Technical data

Material properties: halogen-free, no corrosive and toxic gases
 Shore hardness A: 70° ±5%
 Special weight: 1.23kg/l
 Elongation at break: 237% DIN 53504
 Breaking stress: 11.2MPa DIN 53504

Item no. 116753
 Exterior dimensions: 9.3mm×17.1mm
 Groove width: 6-8mm
 Nominal section: 89mm²
 Weight: 109kg/km

Item no. 140862
 Exterior dimensions: 14.5mm×17.1mm
 Groove width: 10-12mm
 Nominal section: 146mm²
 Weight: 177kg/km

Item no. 155809
 Exterior dimensions: 17.35mm×17.5mm
 Groove width: 14-16mm
 Nominal section: 171mm²
 Weight: 254kg/km

Installation material

Protective hose

Depending on the type of installation, the system cable can also be conducted in an installation tube.



item no. 035976



item no. 128266

Item no.	Designation
035976	Installation tube Ø25/19 mm, fluted, flame-retardant, highly flexible, grey (selling unit 100m)
128266	Corrugated hose Ø21.2/16.5 mm, PA6 flexible, black (selling unit 50m)

Item no.	Designation
116753	Joint profile EPDM 70° Shore for groove 6-8mm, 9.3×17.1 mm, black
140862	Joint profile EPDM 70° Shore for groove 10-12mm, 14.5×17.1 mm, black
155809	Joint profile EPDM 70° Shore for groove 14-16 mm, 17.35×17.5 mm, black

Sealing compound



The recommended sealing compound is heated to 160°–180°C while being constantly mixed. The compound is applied using a spouted container or grouting lance. Excess compound must be removed by scraping once it has fully cooled.

Technical Data

Colour: black
 Form of delivery: 1 box with 24 cubes of 700 g each
 Sealing temperature: 160°C - 180°C
 Weight per unit volume: 1.2g/cm³

Item no.	Designation
208907	Hot/liquid/bitumen sealing compound TOK-Melt N2

Mortar

In order to install the lower part of the TrafficLED, you need mortar to fill in. For each lower part you will need approx. 0.7l (~1.17kg).

Two-component mortar

If the luminaire is to be installed in an area of the road with constant heavy traffic, we recommend using a two-component repair and adhesive mortar such as Bücofix or similar.

Item no.	Designation
161035	Mortar PCI Polifix Plus L (bag of 25 kg)
184454	2-component reactive resin Bücofix SRV black (bucket of 5 kg)

Insulating gel

When not mounted on the wall, the box must be cast with removable sealing compound, e.g. BLUE GEL:



Item no.	Designation
166534	Insulating gel BLUE GEL, solvent-free, bottle of 1 litre; per LED module 0.15 litres are required



GET IN TOUCH WITH US

News about the assortment and specific solutions can be found on our website:

www.gifas.ch

We reserve the right to make technical modifications. V 0621



GIFAS
ELECTRIC

GIFAS-ELECTRIC GmbH
Dietrichstrasse 2
CH-9424 Rheineck

+41 71 886 44 44
+41 71 886 44 49
info@gifas.ch
www.gifas.ch